



ASCENT TOUCH PRE-INSTALLATION AGREEMENT

Congratulations on your purchase of a Concordia beverage system! This Pre-Installation Agreement is designed to prepare your site and staff for an effective installation, and for the ongoing use of your beverage system. Following this guide will best prepare your site and contractor for an efficient and cost-effective installation. Our Customer Care team can answer your questions about ensuring your site is ready for installation and can be reached at InstallationCoordination@concordiacoffee.com.

This agreement is valid for the Concordia Ascent Touch. The Electrical Requirements are valid only for installations in the United States. This is a binding agreement between you (the customer or end user) and Concordia Beverage Systems (Concordia). **Please read this carefully before submitting the signed Agreement and scheduling your installation.** Third-party signatures require approval from Concordia Beverage Systems. If you have any questions or concerns regarding the following Terms and Conditions, please contact Concordia Global Customer Care at email InstallationCoordination@concordiacoffee.com.

TERMS AND CONDITIONS

Section 1

Installation Services

Concordia does not provide electrical, plumbing, and carpentry work. The installation service in this Agreement is limited to the following: (a) the initial, first-time installation of the Ascent Touch; (b) calibration of the Ascent Touch to your beans and cup sizes; (c) installation of the water filtration system, if you chose to order a water filtration system; (d) basic orientation and training (please reference Section 4, below). The signed and approved Pre-Installation Agreement must be received by Concordia Beverage Systems five business days prior to the requested installation date.

Section 2

Installation Service Hours

Standard service hours are Monday through Friday 8:00AM-5:00PM, excluding holidays. Scheduling is based on AM or PM requests.

Section 3

Pricing

Concordia Installations are billed at the time of machine order. If a second installation appointment is required due to non-compliance with Section 5, Pre-Site requirements, or availability of supplied consumables, the normal service hourly rate, plus travel costs, will be billed. Waiting time for consumable supplies, site readiness, contractors, or by customer request will be billed at the same hourly service rate. Additional services such as white-glove and scheduled overtime hours are available upon request. Please contact Concordia Global Customer Care at 1-800-778-0990 or email InstallationCoordination@concordiacoffee.com for availability and a quote.

Section 4

Customer Orientation and Training

After installing the Ascent Touch, the technician will train the onsite available staff on the following tasks:

- The features of the machine
- How to operate the machine
- How to refill the consumables (beans, water filters)
- How to complete daily cleaning.
- Preventive Maintenance overview
- How to contact Concordia Global Customer Care to request service or PM during first year warranty.
- Where to locate the serial number of the machine

Section 5

Customer Responsibility

The customer is responsible for complying with the following Pre-Site Physical Requirements. Read each requirement carefully. Failure to comply with any of the requirements may result in a second visit and an additional fee, as described in Section 3.

Company Name		IF APPLICABLE, PLEASE SUPPLY
Site Contact Name		Construction Company Name
Site Address		
Billing Address		Construction Contact Name
Phone		Phone
Fax		Fax

SITE PHYSICAL REQUIREMENTS

<input type="checkbox"/>	LOCATION: The countertop must support at least 150lbs. Minimum countertop space: 12.5" (32cm) W x 30" (76cm) D x 45" (114cm) H. Actual machine dimensions are smaller , extra space is required for Service Access. Access holes for the drain and water hoses, and pass through chute (<i>optional</i>) must be cut into the countertop. See Access Holes Diagram .
<input type="checkbox"/>	ELECTRICAL: NEMA L6-30R receptacle / L6-30P plug. Minimum 208Vac on dedicated 30amp circuit. Must be located within five feet (1.5 meters) of machine.
<input type="checkbox"/>	ELECTRICAL (optional): NEMA L14-30R receptacle / L14-30P plug. Minimum 208Vac on dedicated 30amp circuit. Must be located within five feet (1.5 meters) of machine.
<input type="checkbox"/>	WATER: Cold water source with a 3/8" compression fitting. Min. 30psi, Max. 100psi, 25gpm. If your location has a Reverse Osmosis System, a freshwater bypass is required. Water hardness must not exceed 3ppg. If water hardness is greater than 3ppg, a water treatment system is required.
<input type="checkbox"/>	WATER TREATMENT SYSTEM (optional): Space should be available to install water treatment system. Must be located within five feet (1.5 meters) of machine. Dimensions: 14" (36cm) W x 6" (16cm) D x 18" (46cm) H. Unit is mounted on the wall.
<input type="checkbox"/>	DRAIN: Connection for a 3/4" (1.3cm) ID drain hose. Must be located within five feet (1.5 meters) of machine.
<input type="checkbox"/>	AMBIENT AIR TEMPERATURE: The air temperature around the machine must not exceed 95°F (36°C), to ensure the machine operates properly. Humidity up to 95%

CUSTOMER SUPPLIED CONSUMABLES

<input type="checkbox"/> BEANS	Whole coffee beans. A minimum of 3lbs of each bean type the machine will use is required.
<input type="checkbox"/> CUPS	Up to Four cup sizes (12oz/360mL, 16oz/480mL and 20oz/590mL, 24 oz/709mL). Minimum 10 each.

ASCENT TOUCH INSTALLATION DIMENSIONS

Optional bin extension adds 6 inches to top.

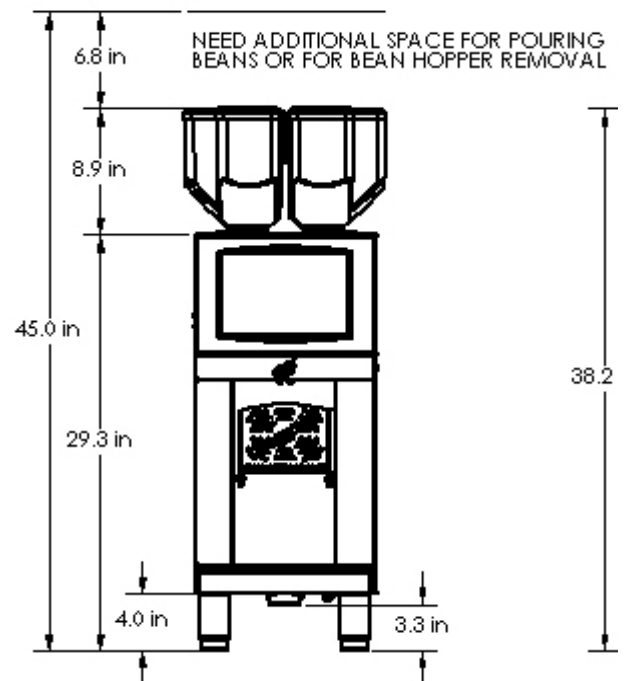

SITE ELECTRICAL REQUIREMENTS

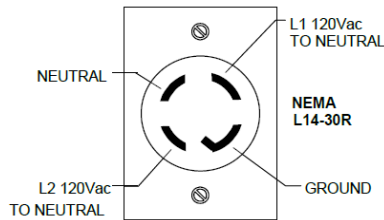
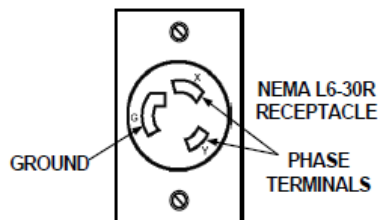

(Optional electrical) – Optional plug must be called out at time of machine order for correct configuration

Access Holes Diagram

The location may require holes for drain hose access and for the pass through chute (optional) to be cut in the counter top.

Connection for a 3/4" (1.9cm) ID drain hose must be located within five feet (1.5 meters) of the machine.

These must be completed prior to installation.

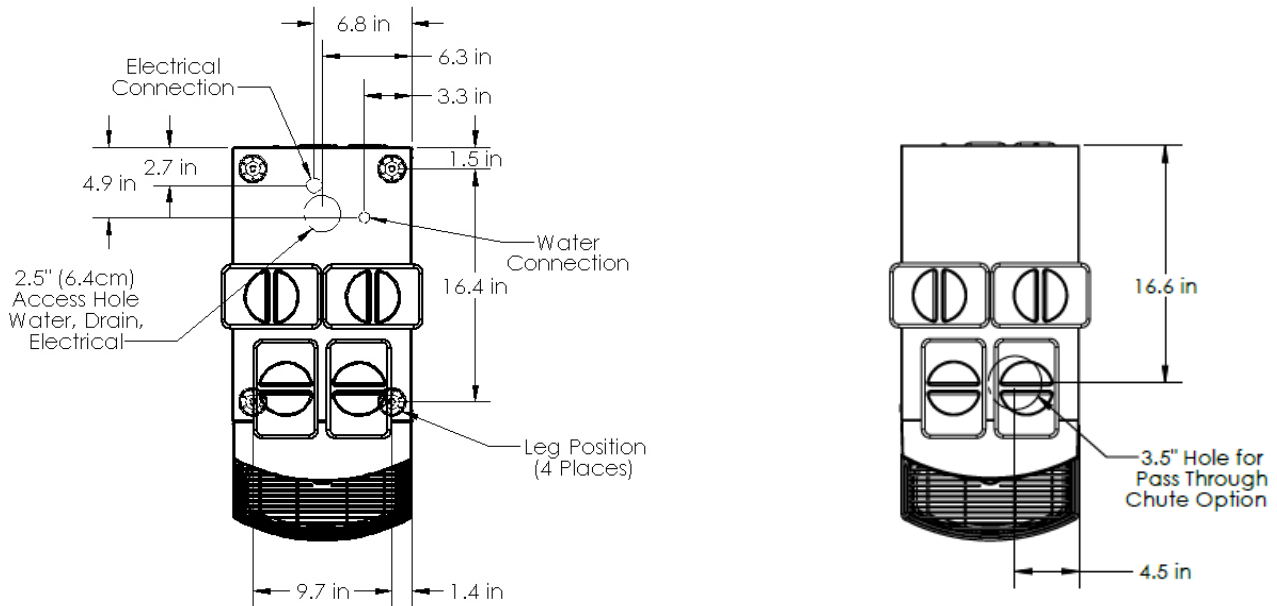

Approved Drain Configurations

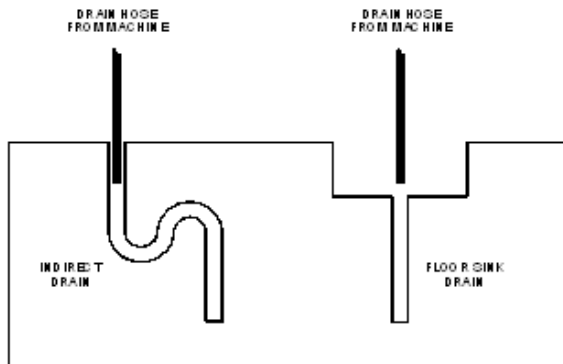

I HAVE READ AND UNDERSTAND THIS DOCUMENT. I CONFIRM ALL PRE-SITE **REQUIREMENTS HAVE BEEN MET.**

I ASSUME RESPONSIBILITY FOR ANY ADDITIONAL FEES INCURRED DUE TO INCOMPLIANCE WITH ANY PRE-SITE REQUIREMENT.

Customer Name (Print): _____ Title: _____

Customer Signature: _____ Date: _____